



(19) **United States**

(12) **Patent Application Publication**
LEE et al.

(10) **Pub. No.: US 2013/0099218 A1**
(43) **Pub. Date: Apr. 25, 2013**

(54) **ORGANIC LIGHT-EMITTING DISPLAY
DEVICE AND METHOD OF FABRICATING
THE SAME**

Publication Classification

(71) Applicant: **LG Display Co., Ltd.**, Seoul (KR)

(51) **Int. Cl.**
H01L 51/52 (2006.01)
H01L 51/50 (2006.01)

(72) Inventors: **Joon-Suk LEE**, Seoul (KR); **Se-June
KIM**, Paju-Si (KR); **JuhnSuk YOO**,
Goyang-si (KR)

(52) **U.S. Cl.**
CPC *H01L 51/5203* (2013.01); *H01L 51/5012*
(2013.01)
USPC **257/40**; 257/99; 438/22

(73) Assignee: **LG DISPLAY CO., LTD.**, Seoul (KR)

(57) **ABSTRACT**

(21) Appl. No.: **13/707,310**

An organic electro-luminescence device capable of reducing a resistance of a cathode electrode to enhance brightness uniformity at each location within the device is described. The organic electro-luminescence device includes a bank layer formed over a substrate, the bank layer including a first, second, and third portion. A first electrode is formed between the first and second portions of the bank layer. An auxiliary electrode is formed where at least a part of the auxiliary electrode is formed between the second and third portions of the bank layer. A voltage drop prevention pattern is formed on the auxiliary electrode. An organic material layer formed between the first and second portions of the bank layer. A second electrode formed on the organic material layer, where at least a portion of the second electrode is electrically coupled to the auxiliary electrode.

(22) Filed: **Dec. 6, 2012**

Related U.S. Application Data

(63) Continuation-in-part of application No. 13/415,655, filed on Mar. 8, 2012.

(30) **Foreign Application Priority Data**

Sep. 2, 2011 (KR) 10-2011-0089277

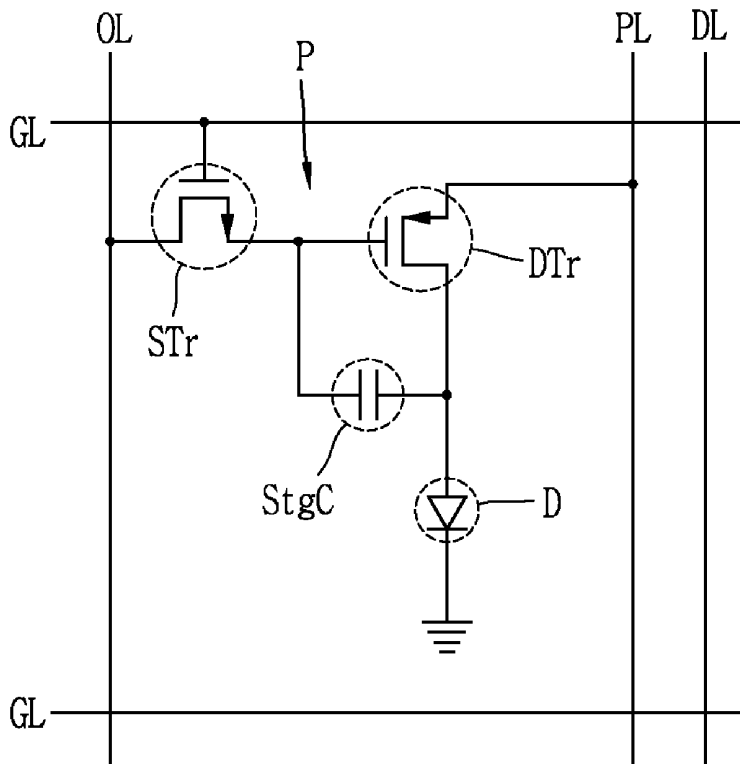

FIG. 1

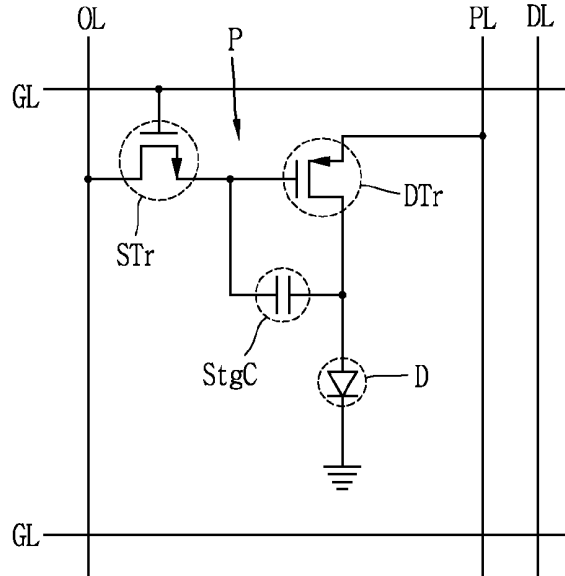

FIG. 2

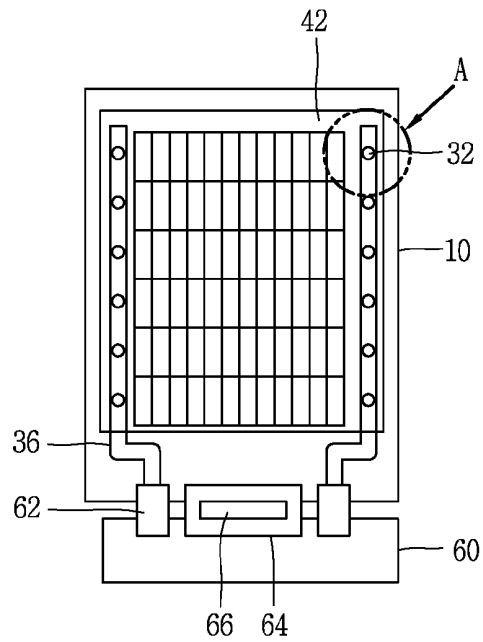

FIG. 3

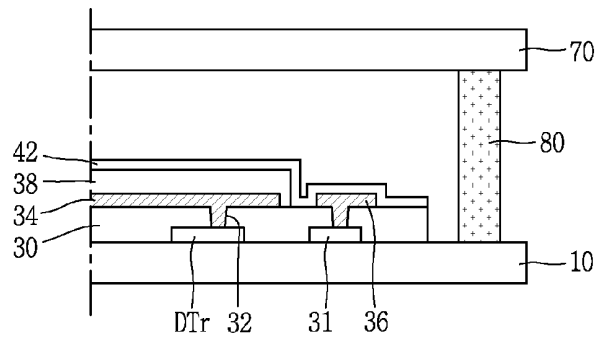

FIG. 4

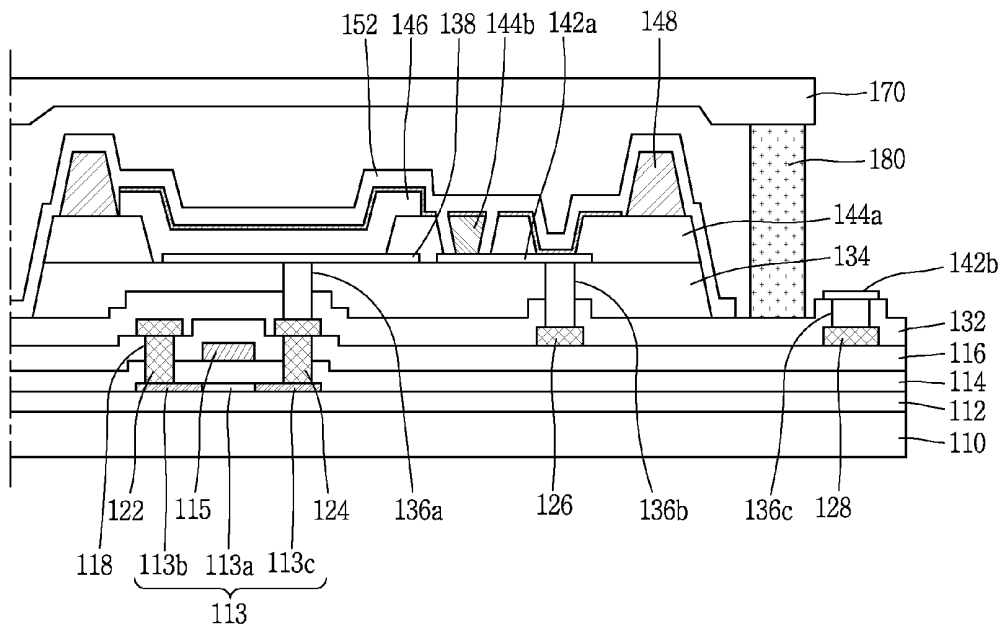

FIG. 5

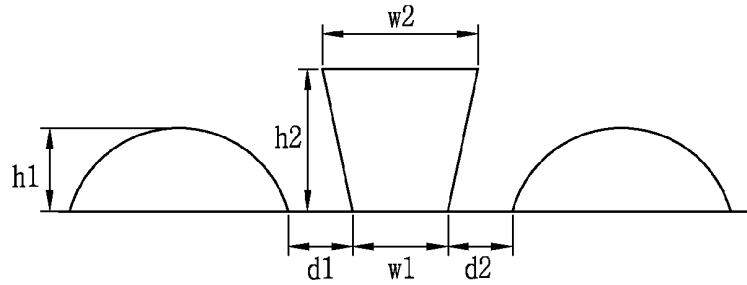

FIG. 6A

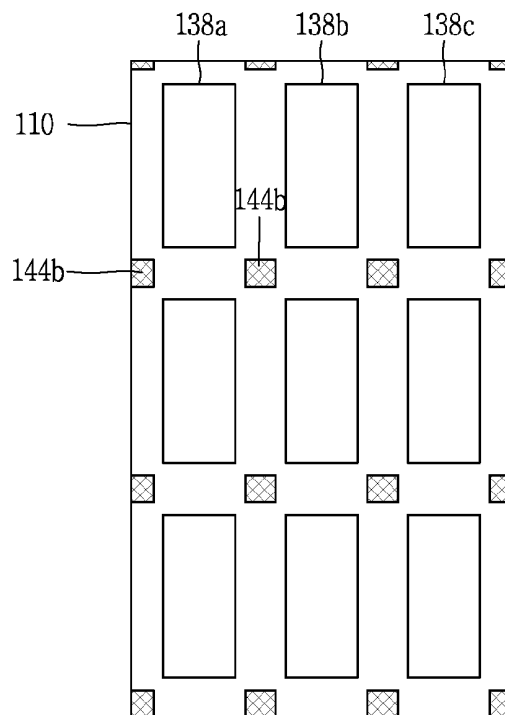

FIG. 6B

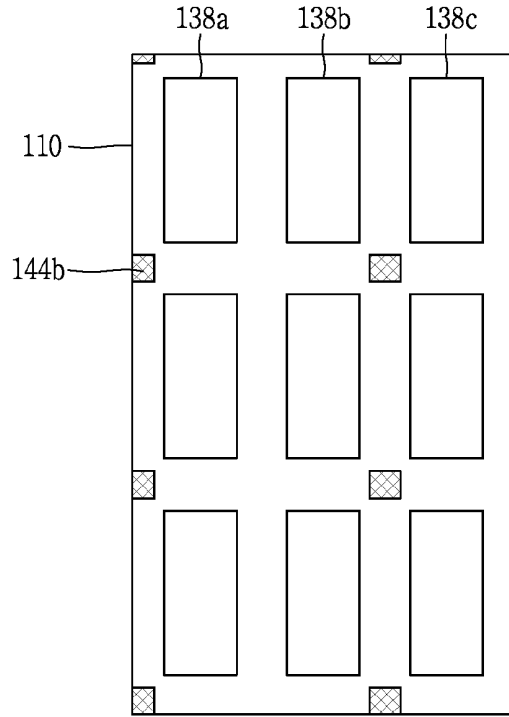

FIG. 6C

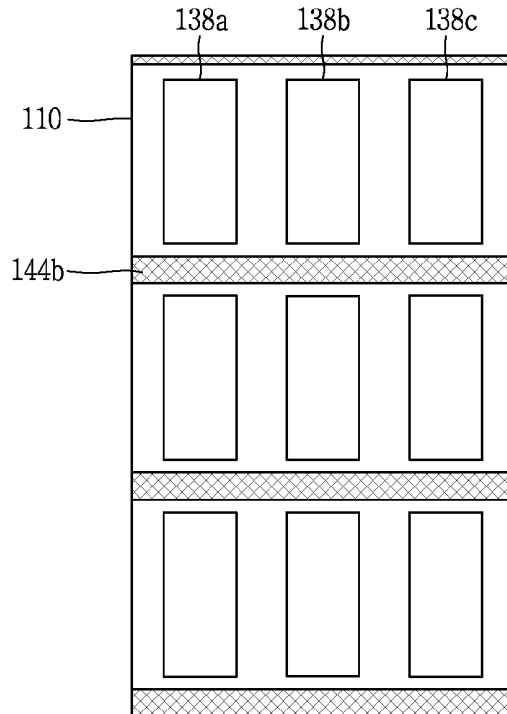

FIG. 6D

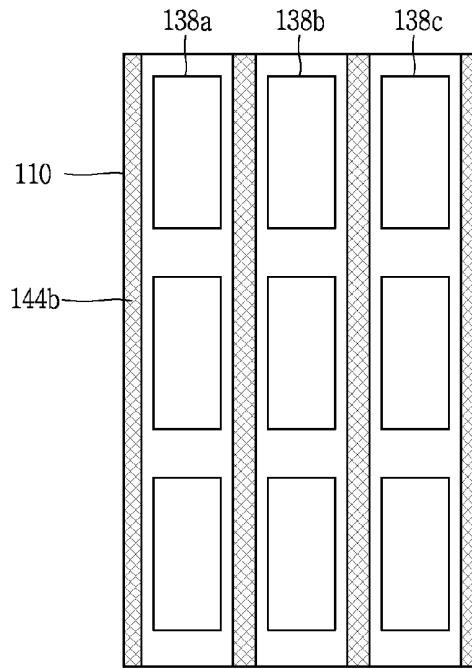

FIG. 6E

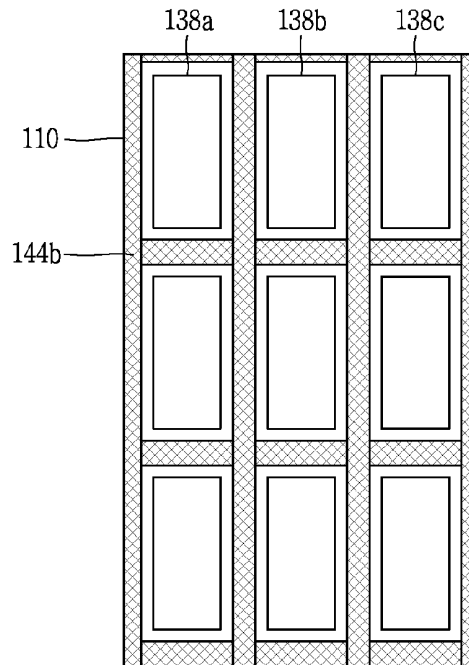

FIG. 7A

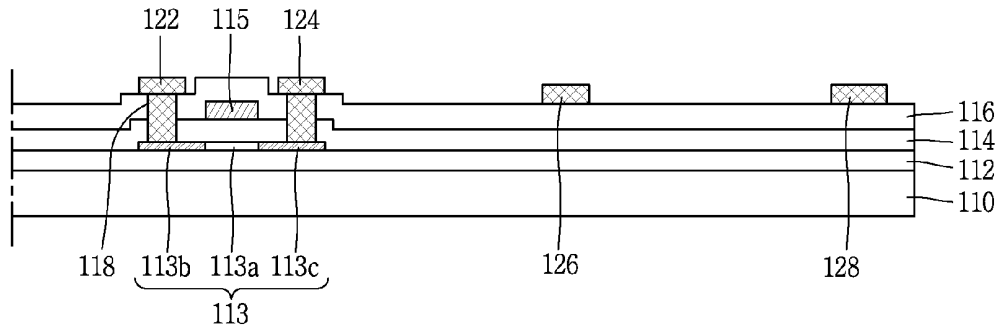

FIG. 7B

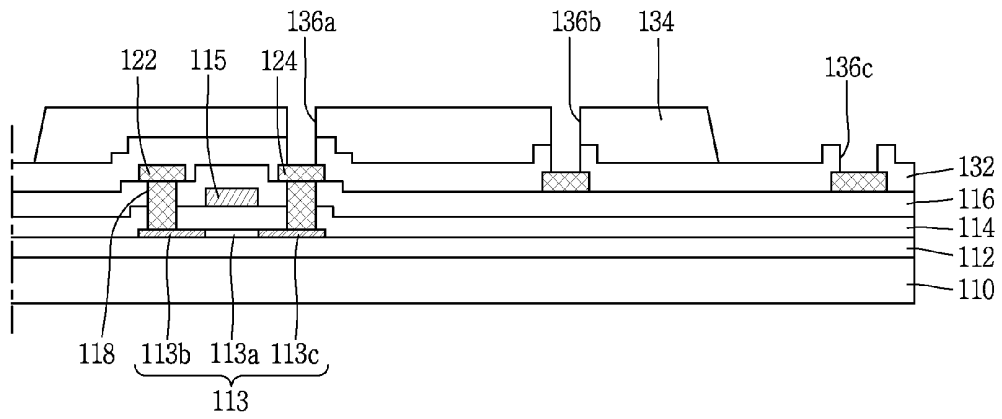

FIG. 7C

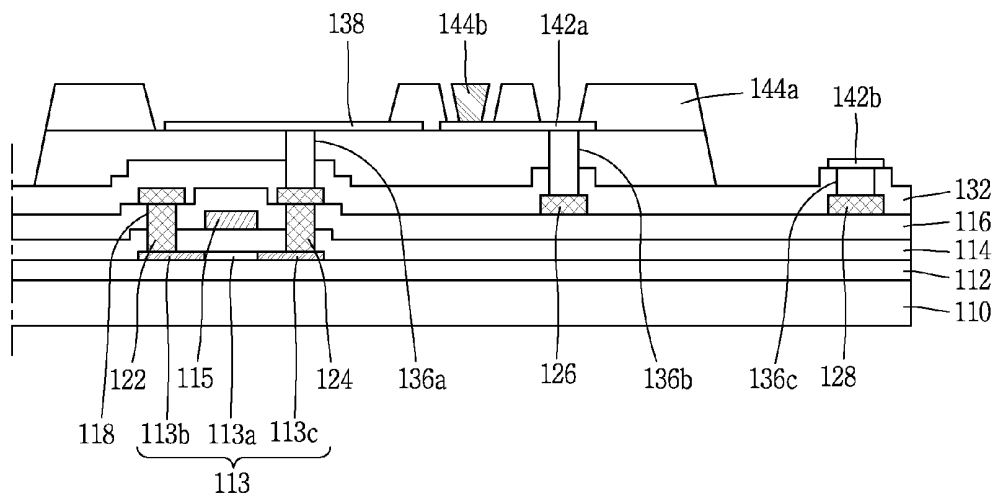

FIG. 7D

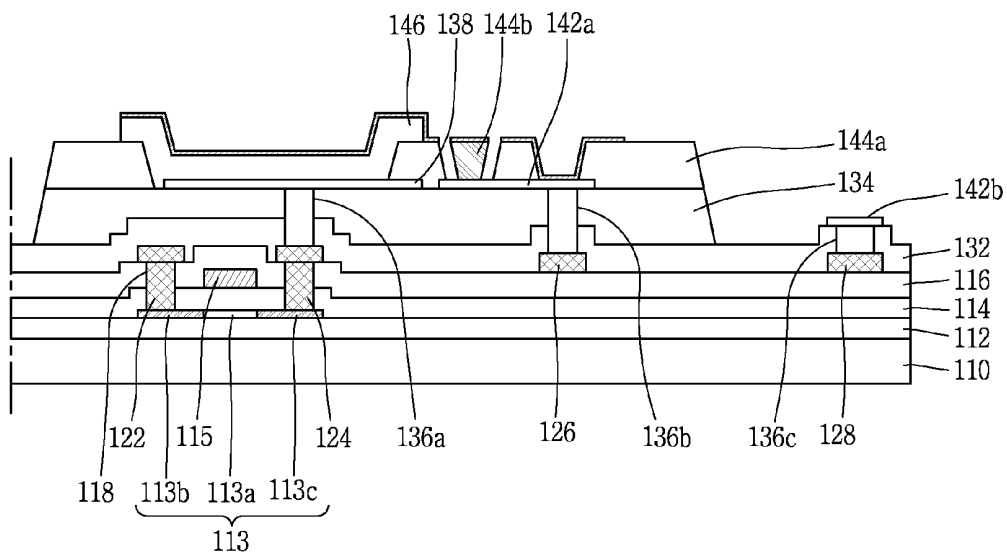

FIG. 7E

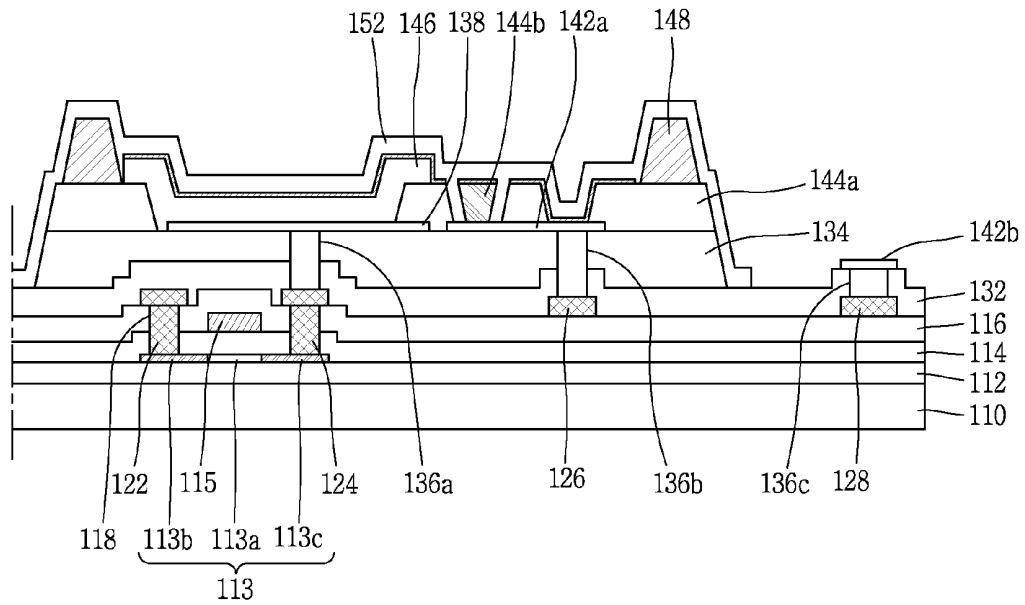

FIG. 8A

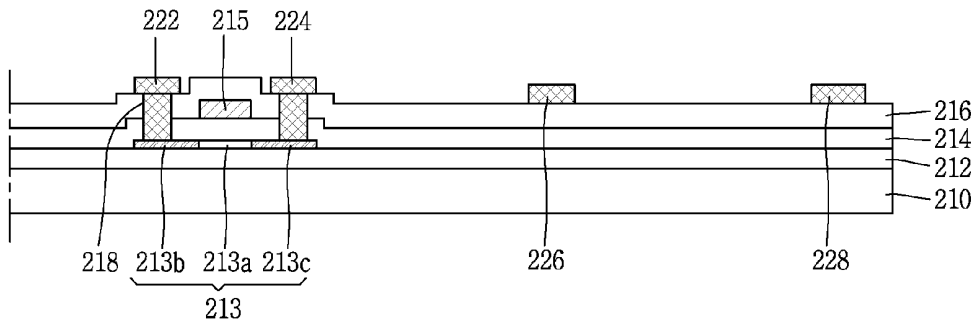

FIG. 8B

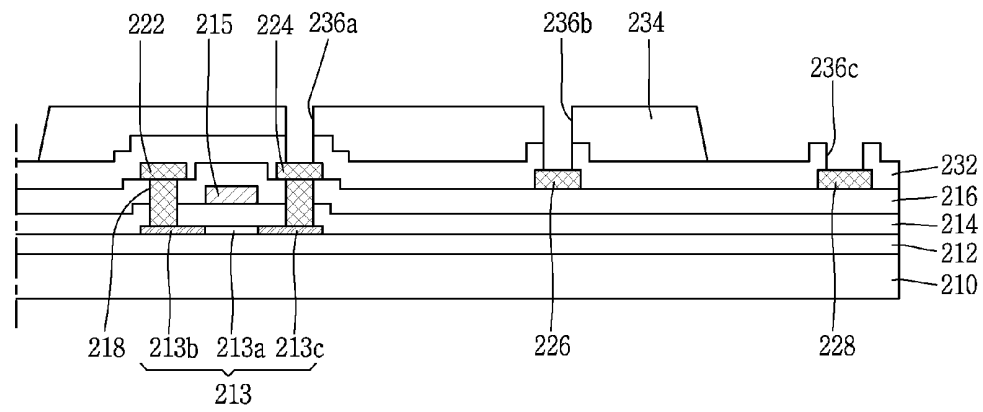

FIG. 8C

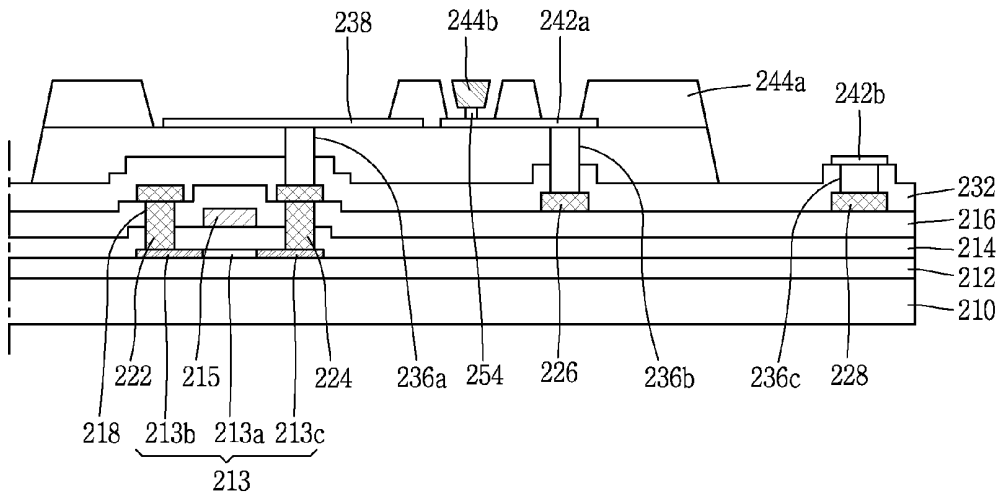

FIG. 8D

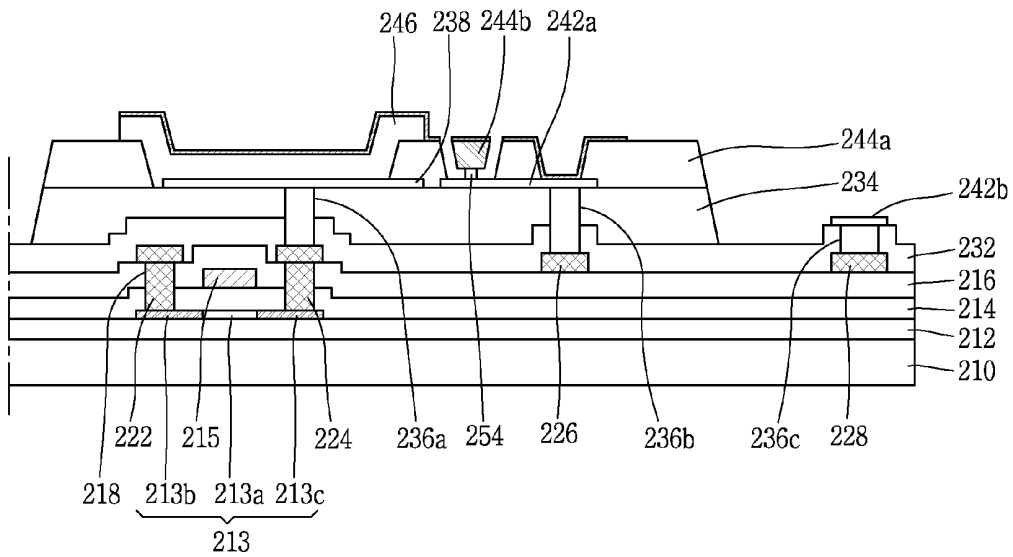

FIG. 8E

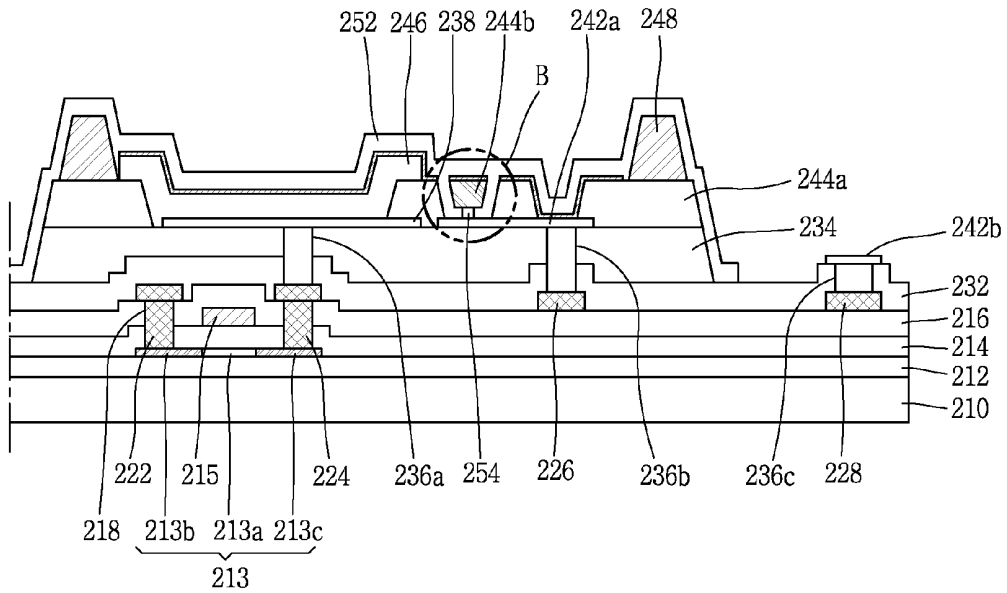
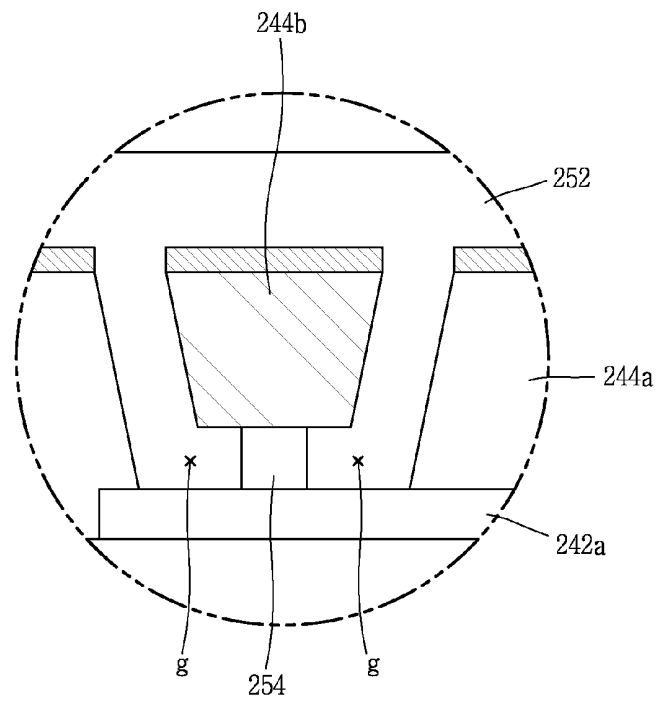

FIG. 9



**ORGANIC LIGHT-EMITTING DISPLAY
DEVICE AND METHOD OF FABRICATING
THE SAME**

CROSS REFERENCE TO RELATED
APPLICATIONS

[0001] This application is a continuation-in-part application of, and claims the benefit under 35 U.S.C. §120 from, co-pending U.S. patent application Ser. No. 13/415,655, entitled "Organic Light-Emitting Display Device and Method of Fabricating the Same," filed on Mar. 8, 2012, which application claims the benefit of Korean Patent Application No. 10-2011-0089277, filed on Sep. 2, 2011, the subject matters of both of which are hereby incorporated by reference in their entirety.

BACKGROUND OF THE DISCLOSURE

[0002] 1. Field of the Disclosure

[0003] The present invention relates to an organic electro-luminescence device and a method of fabricating the same.

[0004] 2. Discussion of the Related Art

[0005] In recent years, there has been increased use of portable electronic devices such as notebooks and personal mobile devices. These devices include display devices. In order to maximize their per-battery charge lifespan, ideally these display device are constructed using light weight and low power consumption technologies, for example using flat panel displays (FPDs) such as liquid crystal displays (LCD) and organic electro-luminescence devices.

[0006] Organic electro-luminescence devices have advantages over other display technologies including, for example, having high brightness, having low operation voltage characteristics, having a high contrast ratio because of being operated as a self luminous type display that spontaneously emits light, capability of being implemented in an ultra-thin display, facilitating the implementation of moving images using a response time of several microseconds (μ s), having no limitation in viewing angle, having stability even at low temperatures, and allowing flexible fabrication and design of a driving circuit due to operation at low direct current voltages, for example between 5 to 15 V.

[0007] The organic electro-luminescence device may be classified into a passive matrix type or an active matrix type. In the passive matrix type, the device may be configured with a matrix form in which the gate and data lines are crossed with each other, and the gate lines are sequentially driven as time passes to drive each pixel. Thus, to achieve a given instantaneous brightness an amount of power equaling the average brightness multiplied by the number of lines may be required at all time to display the instantaneous brightness.

[0008] In an active matrix type uses thin-film transistors used for switching individual pixels on and off, a first electrode coupled to the thin-film transistor may be turned on or off for each sub-pixel unit, and a second electrode facing the first electrode may become a common electrode. Further, a voltage applied to the pixel may be charged at a storage capacitance (CST), and applied until the next frame signal is applied. Thus, in contrast to the passive matrix type, in an active matrix type a pixel may be continuously driven for one frame regardless of the number of gate lines. As a result, the same brightness can be obtained even if a comparatively lower current is applied. This has the advantage of providing a low power consumption even in a large screen sized display.

In recent years, active matrix type organic electro-luminescence devices have been increasingly widely used for at least this reason.

[0009] FIG. 1 is a circuit diagram illustrating one pixel of a typical active matrix type organic electro-luminescence device. Referring to FIG. 1, one pixel of the active matrix type organic electro-luminescence device may include a switching thin-film transistor (STr), a driving thin-film transistor (DTr), a storage capacitor (StgC), and an organic electro-luminescence diode (D). A gate line (GL) may be formed in a first direction, and a data line (DL) may be formed in a second direction crossed with the first direction to form a pixel area (P), and a power line (PL) separated from the data line (DL) may be formed to apply a power voltage.

[0010] A switching thin-film transistor (STr) and a driving thin-film transistor (DTr) electrically coupled to the switching thin-film transistor (STr) may be formed at a portion where the data line (DL) and gate line (GL) intersect. A first electrode which is a terminal of the organic electro-luminescence diode (D) may be coupled to a drain electrode of the driving thin-film transistor (DTr), and a second electrode which is the other terminal thereof may be coupled to the power line (PL). Here, the power line (PL) may transfer a power voltage to the organic electro-luminescence diode (D). Also, a storage capacitor (StgC) may be formed between the gate electrode and the source electrode of the driving thin-film transistor (DTr).

[0011] When a signal is applied via the gate line (GL), the switching thin-film transistor (STr) is turned on, and a signal of the data line (DL) is transferred to a gate electrode of the driving thin-film transistor (DTr) to turn on the driving thin-film transistor (DTr), thereby emitting light through the organic electro-luminescence diode (D). At this time, when the driving thin-film transistor (DTr) enters an ON state, the level of a current flowing through the organic electro-luminescence diode (D) from the power line (PL) is determined, thereby determining a gray scale. The storage capacitor (StgC) may perform the role of constantly maintaining a gate voltage of the driving thin-film transistor (DTr) when the switching thin-film transistor (STr) is turned off, thereby constantly maintaining the level of the current flowing through the organic electro-luminescence diode (D) until the next frame, even if the switching thin-film transistor (STr) enters an OFF state before then. The organic electro-luminescence device performing such a driving operation may be classified into a top emission type and a bottom emission type.

[0012] FIG. 2 is a plan view illustrating a top emission type organic electro-luminescence device, and FIG. 3 is a cross-sectional view illustrating one pixel area including a driving thin-film transistor of the top emission type organic electro-luminescence device, as a cross-sectional view of an "A" portion of FIG. 2. Referring to FIGS. 2 and 3, a first and a second substrate **10, 70** are disposed to face each other, and an edge portion of the first and the second substrate **10, 70** is sealed by a seal pattern **80**.

[0013] The driving thin-film transistor (DTr) is formed for each pixel area (P) and a first electrode **34** coupled to each driving thin-film transistors (DTr) via a contact hole **32** is formed at an upper portion of the first substrate **10**, and an organic emitting layer **38** coupled to the driving thin-film transistor (DTr) and containing light-emitting materials corresponding to red, green and blue colors is formed at an upper

portion of the first electrode **34**, and a second electrode **42** is formed at a front surface of the upper portion of the organic emitting layer **38**.

[0014] The first and the second electrode **34**, **42** perform the role of applying a voltage to the organic emitting layer **38**. A first auxiliary electrode **31** applies a voltage to the second electrode **42**. The first auxiliary electrode **31** is formed at the same layer as the driving thin-film transistor (DTr). A second auxiliary electrode **36** is coupled to the first auxiliary electrode **31** via a contact hole **32**. The second auxiliary electrode is formed at the same layer as the first electrode **34**. Accordingly, the second electrode **42** receives a voltage via the first auxiliary electrode **31** and second auxiliary electrode **36**.

[0015] Here, the second electrode **42** may be formed of a metal, particularly, with a thin thickness, for example, a thickness of less than 100 Å, to have a semi-transmissive property. If the second electrode **42** is formed with a low thickness, then a sheet resistance increases, and as a consequence the second electrode **42** receives a voltage via the second auxiliary electrode **36** and the first auxiliary electrode **31** formed at the outside of the panel, thereby causing a voltage drop as a result of the distance difference (and consequent resistance) between an edge region of the panel and a central portion. As a result, a brightness difference may be created between an edge region of the panel and a central portion thereof. This causes the image produced by the device to appear nonuniform with respect to brightness across the entire device.

SUMMARY

[0016] An organic electro-luminescence device capable of reducing a resistance of a cathode electrode to enhance brightness uniformity at each location within the device is described. The organic electro-luminescence device includes a bank layer formed over a substrate, the bank layer including a first, second, and third portion. A first electrode is formed between the first and second portions of the bank layer. An auxiliary electrode is formed where at least a part of the auxiliary electrode is formed between the second and third portions of the bank layer. A pattern is formed on the auxiliary electrode. An organic material layer is formed between the first and second portions of the bank layer. A second electrode is formed on the organic material layer, where at least a portion of the second electrode is electrically coupled to the auxiliary electrode.

BRIEF DESCRIPTION OF THE DRAWINGS

[0017] The accompanying drawings, which are included to provide a further understanding of the invention and are incorporated in and constitute a part of this specification, illustrate embodiments of the invention and together with the description serve to explain the principles of the invention.

[0018] FIG. 1 is a circuit diagram illustrating one pixel of a typical active matrix type organic electro-luminescence device.

[0019] FIG. 2 is a plan view illustrating a top emission type organic electro-luminescence device.

[0020] FIG. 3 is a cross-sectional view illustrating one pixel area including a driving thin-film transistor of the top emission type organic electro-luminescence device, as a cross-sectional view of an "A" portion of FIG. 2.

[0021] FIG. 4 is a cross-sectional view illustrating one pixel area including a driving thin-film transistor of an organic electro-luminescence device according to an embodiment of the present invention.

[0022] FIG. 5 is a cross-sectional view illustrating an actual voltage drop prevention pattern and bank.

[0023] FIGS. 6A through 6E are plan views illustrating the shape of a voltage drop prevention pattern according to an embodiment of the present invention.

[0024] FIGS. 7A through 7E are process cross-sectional views for each fabrication step illustrating one pixel area of an organic electro-luminescence device according to a first embodiment of the present invention.

[0025] FIGS. 8A through 8E are process cross-sectional views for each fabrication step illustrating one pixel area of an organic electro-luminescence device according to a second embodiment of the present invention.

[0026] FIG. 9 is an enlarged cross-sectional view illustrating a portion B in FIG. 8E.

DETAILED DESCRIPTION

[0027] FIG. 4 is a cross-sectional view illustrating one pixel area including a driving thin-film transistor of an organic electro-luminescence device according to an embodiment of the present invention. FIG. 5 is a cross-sectional view illustrating an actual voltage drop prevention pattern and bank. FIGS. 6A through 6E are plan views illustrating the shape of a voltage drop prevention pattern according to embodiments of the present invention.

[0028] Referring to FIG. 4, an organic electro-luminescence device according to an embodiment of the present invention is a top emission type, and includes driving and switching transistors (DTr) (as described below, **113**, **114**, and **115** in combination form the transistors), a first substrate **110** formed with an organic electro-luminescence diode (D), and a second substrate **170** for encapsulation.

[0029] A buffer layer **112** is formed on a driving area (DA) of the first substrate **110**. A semiconductor layer **113** consisting of a first area **113a** with pure polysilicon and second areas **113b**, **113c** doped with impurities is formed on the buffer layer **112**. The buffer layer **112** is a layer for preventing the semiconductor layer **113** from being deteriorated due to the emission of alkali ions generated into an inner portion of the first substrate **110** when crystallizing the semiconductor layer **113**.

[0030] A gate insulating layer **114** is formed on the semiconductor layer **113**, and a gate electrode **115** is formed on the gate insulating layer **114** corresponding to the first area **113a** of the semiconductor layer **113**. An interlayer insulating layer **116** is formed on the gate electrode **115**. A first contact hole **118** to expose the second areas **113b**, **113c** of the semiconductor layer **113** is formed on the interlayer insulating layer **116** and the gate insulating layer **114** at a lower portion of thereof.

[0031] A data line intersecting with a gate line (not shown) including the gate electrode **115** to define a pixel area is formed on the interlayer insulating layer **116**. The data line may include a source and drain electrodes **122**, **124** electrically coupled to the second areas **113b**, **113c**, respectively, of the semiconductor layer **113** through the first contact hole **118**. Here, the source and drain electrodes **122**, **124** may be formed with a multi-layer structure made of titanium (Ti), aluminium (Al), and titanium (Ti).

[0032] A first auxiliary electrode **126** and a second auxiliary electrode **128** are formed on the interlayer insulating layer **116**. The first auxiliary electrode **126** is separated from the drain electrode **124** and the second auxiliary electrode **128** is separated from the first auxiliary electrode **126**. A constant voltage, for example, a voltage V_{ss} is applied to the first and the second auxiliary electrode **126**, **128** from an external circuit.

[0033] The source and drain electrodes **122**, **124**, the semiconductor layer **113**, the gate insulating layer **114**, and the gate electrode **115** together constitute a driving transistor (DTr) and/or a switching transistor. The driving transistor (DTr) and switching transistor may form a P- or N-type transistor based on the doped impurities. A P-type transistor may be formed by doping a group III element, for example, boron (B), into the second areas **113b**, **113c** of the semiconductor layer **113**. An N-type transistor may be formed by doping a group V element, for example, phosphor (P), into the second areas **113b**, **113c** of the semiconductor layer **113**. The P-type transistor uses holes as a carrier, and the N-type transistor uses electrons as a carrier.

[0034] A first and a second passivation layers **132**, **134** are formed at an upper portion of the driving transistor (DTr) and switching transistor. A second contact hole **136a** for exposing the drain electrode **124** of the driving transistor (DTr) is formed on the first and second passivation layers **132**, **134**. A third contact hole **136b** for exposing the first auxiliary electrode **126** is formed on the first and the second passivation layer **132**, **134**. A fourth contact hole **136c** for exposing the second auxiliary electrode **128** is formed on the first passivation layer **132**.

[0035] A first electrode **138** is formed on the second passivation layer **134**. The first electrode **138** is electrically coupled to the drain electrode **124** through the second contact hole **136a**. In this case, the first electrode **138** may be formed with a multilayer structure made of indium tin oxide (ITO), silver (Ag) and indium tin oxide (ITO) to implement the transmission of light. Also, a third auxiliary electrode **142a** is formed on the second passivation layer **134**. The third auxiliary electrode **142a** is separate from the first electrode **138**, however it is electrically coupled to the first auxiliary electrode **126** through the third contact hole **136b**. Further, a fourth auxiliary electrode **142b** is formed on the first passivation layer **132**. The fourth auxiliary electrode **142b** is electrically coupled to the second auxiliary electrode **128** through the fourth contact hole **136c**.

[0036] A bank **144a** is formed on both sides of the first electrode **138**. The bank may also be formed to be overlapped with a side edge of the first electrode **138** in the shape of surrounding each pixel area. The banks **144a** may be said to have multiple portions, where a first portion of the bank may be on one side of the pixel area, and the second portion of the bank may be on the other side of the pixel area.

[0037] A voltage drop prevention pattern **144b** (or simply pattern **144b**) is formed on a side upper portion of the third auxiliary electrode **142a**. The pattern may be formed between the second portion of the bank **144a** and a third portion of the bank **144a**. The voltage drop prevention pattern **144b** prevents a voltage drop from being produced by a sheet resistance of the second electrode **152**. The voltage drop prevention pattern **144b** may be formed of a negative photo resist. The voltage drop prevention pattern **144b** formed at a side upper portion of the third auxiliary electrode **142a** is formed so as to be separate from the bank **144a**. The voltage drop

prevention pattern **144b** may also be formed to have an inverse tapered shape. The taper angle of the voltage drop prevention pattern **144b** may vary depending upon the implementation.

[0038] The pattern **144b** prevents the organic portions of the display device (described further below) from forming in between the second and third portions of the bank. This, for example, prevents the organic portions of the display device from coming into physical contact with the third auxiliary electrode **142a**. The pattern **144b** does not prevent, however, the second electrode **152** from forming and coupling physically and electrically to the third auxiliary electrode **142a**. The pattern **144b** thus serves to allow for a much larger contact area between the second electrode **152** and the third auxiliary electrode **142a**. Due to the larger contact area between the second electrode **152** and the third auxiliary electrode **142a**, the sheet resistance encountered by having a small contact area is reduced. As a result, there is little to no voltage drop at the point of contact between the second electrode **152** and the third electrode **142a**.

[0039] As illustrated in FIG. 5, the height (h_1) of the banks **144a** formed on both sides of the voltage drop prevention pattern **144b** are formed shorter than the height (h_2) of the voltage drop prevention pattern **144b**. For example, the height (h_1) of the banks **144a** may be $1.74\ \mu\text{m}$, whereas the height (h_2) of the voltage drop prevention pattern **144b** may be $1.86\ \mu\text{m}$. Continuing with the same example, a bottom width (w_1) of the voltage drop prevention pattern **144b** may be $7.078\ \mu\text{m}$ whereas a top width (w_2) of the voltage drop prevention pattern **144b** may be $7.968\ \mu\text{m}$. Further, a distance (d_1) between the voltage drop prevention pattern **144b** and the bank **144a** may be $5.203\ \mu\text{m}$, whereas a distance (d_2) between the voltage drop prevention pattern **144b** and the bank **144a** may be $5.109\ \mu\text{m}$.

[0040] As stated above, the bank may include three portions. A second portion of the bank is formed between the first electrode and the voltage drop prevention pattern **144b**. A third portion of the bank is formed on the opposite side of the voltage drop prevention pattern **144b** from the second portion. The second electrode **152** may be formed between the second portion of the bank and the voltage drop prevention pattern **144b**, and may also be formed between the voltage drop prevention pattern **144b** and the third portion of the bank on the third auxiliary electrode **142a**. The second electrode **152** directly and electrically connects to the third auxiliary electrode **142a** to the first auxiliary electrode **126**. The second electrode **152** has little to no contact resistance. Accordingly, it may be possible to prevent a voltage drop when a voltage is applied to the first and the second auxiliary electrode **126**, **128** in the edge area of the panel. Without the voltage drop prevention pattern **144b**, the voltage drop would be caused by a distance difference between an edge region of the panel and a central portion thereof.

[0041] FIGS. 6A through 6E are plan views illustrating the shapes of voltage drop prevention patterns according to embodiments of the present invention. The voltage drop prevention pattern **144b** may be formed in various shapes.

[0042] As illustrated in FIG. 6A, the first electrode **138** formed on the substrate **110** may include first through third sub-electrodes **138a** to **138c**, wherein the first sub-electrode **138a** indicates a pixel electrode corresponding to R, the second sub-electrode **138b** indicates a pixel electrode corresponding to G, and the third sub-electrode **138c** indicates a pixel electrode corresponding to B. The voltage drop preven-

tion pattern **144b** may be formed in the remaining region not containing the sub-electrodes. Put another way, the pattern **144b** may be formed outside the emission area of the display device. The emission area may be determined based on the borders of the organic material, or it may be determined based on the borders of the first, second, and third portions of the bank. The voltage drop prevention pattern **144b** may be formed at horizontal and vertical intersections between the sub-electrodes. The voltage drop prevention pattern **144** may be formed in a rectangular shape, for example.

[0043] As illustrated in FIG. 6B, the voltage drop prevention pattern **144b** may be formed in the remaining region not containing the sub-electrodes. The voltage drop prevention pattern **144b** may be formed at positions where the horizontal and vertical directions are crossed with each other, only periodically between sub electrodes. For example, as illustrated in FIG. 6B, the voltage drop prevention pattern **144b** may be formed between every other set of electrodes in the horizontal direction, and between every electrode in the vertical direction (or vice versa).

[0044] As illustrated in FIG. 6C, the voltage drop prevention pattern **144b** may be formed in the remaining region not containing the sub-electrodes. For example, the voltage drop prevention pattern **144b** may be formed in a horizontal direction between each sub-electrode, and may be formed in a bar shape.

[0045] As illustrated in FIG. 6D, the voltage drop prevention pattern **144b** may be formed in the remaining region not containing the sub-electrodes. For example, the voltage drop prevention pattern **144b** may be formed in a vertical direction between each sub-electrode, and may be formed in a bar shape.

[0046] As illustrated in FIG. 6E, the voltage drop prevention pattern **144b** may be formed in the remaining region not containing the sub-electrodes. For example, the voltage drop prevention pattern **144b** may be formed in a crossed pattern in both the horizontal and vertical directions between each sub-electrode, and may be formed in a bar shape.

[0047] An organic emitting layer **146** made of a multilayer structure is formed at an upper portion of the first electrode **138**. The first electrode **138** coupled to the drain electrode **124** of the driving thin-film transistor (DTr) performs the role of an anode or cathode electrode based on the type of the driving thin-film transistor (DTr). The first electrode **138** performs the role of an anode electrode when the driving thin-film transistor (DTr) is a P-type. The first electrode **138** performs the role of a cathode electrode when the driving thin-film transistor (DTr) is an N-type. When the first electrode **138** performs the role of an anode electrode, the organic emitting layer **146** may include a hole injection layer, a hole transporting layer, an emission layer, an electron transporting layer and an electron injection layer. When the first electrode **138** performs the role of a cathode electrode, the organic emitting layer **146** may include an electron injection layer, an electron transporting layer, an emission layer, a hole transporting layer, and a hole injection layer.

[0048] Spaces **148** are formed at regular intervals on the portions of the bank **144a**.

[0049] The second electrode **152** is formed at a front surface of the substrate including the organic emitting layer **146**. The second electrode **152** may be formed of a transparent conductive material such as indium tin oxide (ITO) or indium zinc oxide (IZO). The second electrode **152** is formed between the bank **144a** and voltage drop prevention pattern

144b and between the voltage drop prevention pattern **144b** and bank **144a** on the third auxiliary electrode **142a**. The second electrode **152** electrically connects the third auxiliary electrode **142a** to the first auxiliary electrode **126**.

[0050] A second substrate **170** is disposed to face the first substrate **110**. An edge portion of the first and the second substrate **110**, **170** is sealed by a seal pattern **180**. A gap is maintained between the second electrode **152** the second substrate **170**.

[0051] According to an embodiment 1 of the present invention, all elements are formed on the first substrate and thus a method of fabricating the first substrate is described. In this example, the device is a top emission type organic electro-luminescence device where the first electrode coupled to a drain electrode of the driving transistor (DTr) performs the role of an anode electrode and the second electrode performs the role of a cathode electrode.

[0052] FIGS. 7A through 7E are process cross-sectional views for each fabrication step illustrating one pixel area of an organic electro-luminescence device according to a first embodiment of the present invention. Referring to FIG. 7A, an inorganic insulating material, for example, silicon oxide (SiO₂) or silicon nitride (SiN_x), is deposited on the insulating substrate **110** to form the buffer layer **112**.

[0053] Amorphous silicon is deposited on the buffer layer **112** to form an amorphous silicon layer (not shown), and then the amorphous silicon is crystallized into a polysilicon layer (not shown) by irradiating a laser beam or performing a thermal processing on the amorphous silicon. A mask process is performed to pattern the polysilicon layer (not shown), thereby forming the semiconductor layer **113** in a pure polysilicon layer state.

[0054] A nonconductive material such as silicon oxide (SiO₂), for example, is deposited on the semiconductor layer **113** with pure polysilicon to form the gate insulating layer **114**. Molybdenum tungsten (MoW), for example, is deposited on the gate insulating layer **114** to form a first metal layer (not shown), and a mask process is performed on the first metal layer to form the gate electrode **115** on the gate insulating layer **114** corresponding to the first area **113a** of the semiconductor layer **113**.

[0055] An impurity, i.e., a group III element or group V element is doped into a front surface of the substrate **110** using the gate electrode **115** as a blocking mask to form the second areas **113b**, **113c**. The second areas **113b**, **113c** are doped with impurities at a portion located at the outside of the gate electrode **120** of the semiconductor layer **113**. Doping is prevented in the first area **113a** containing pure or nearly pure polysilicon at a portion corresponding to the gate electrode **120**.

[0056] An inorganic insulating material, for example, silicon nitride (SiN_x) or silicon oxide (SiO₂) is deposited at a front surface of the substrate **110** formed with the semiconductor layer **113**, divided into the first and the second areas **113a**, **113b**, **113c**, to form the interlayer insulating layer **116**. The interlayer insulating layer **116** and the gate insulating layer **114** are simultaneously or collectively patterned by performing a mask process. The mask process also creates the first contact hole **118** for exposing the second areas **113b**, **113c**, respectively.

[0057] A second metal layer (not shown) having a multi-layer structure, for example, made of titanium (Ti), aluminium (Al), and titanium (Ti), is formed on the interlayer insulating layer **116**. The second metal layer is patterned by

performing a mask process to form the source and drain electrodes 122, 124. The second metal layer is electrically coupled to the second area 113b through the first contact hole 118. The first and the second auxiliary electrode 126, 128 are formed on the interlayer insulating layer 116. The first auxiliary electrode 126 is separate from the drain electrode 124, and the second auxiliary electrode 128 is separate from the first auxiliary electrode 126.

[0058] Referring to FIG. 7B, an inorganic insulating material such as silicon nitride (SiNx), for example, is deposited at a front surface of the substrate 110 including the source and drain electrodes 122, 124 to form the first passivation layer 132. An organic insulating material such as photo acryl (PA), for example, is deposited on the first passivation layer 132 to form the second passivation layer 134. The second contact hole 136a for exposing the drain electrode 124 and the third contact hole 136b for exposing the first auxiliary electrode 126 are formed on the first and the second passivation layers 132, 134. At substantially the same time, the fourth contact hole 136c for exposing the second auxiliary electrode 128 is formed thereon.

[0059] Referring to FIG. 7C, a third metal layer (not shown) having a multilayer structure, for example, made of indium tin oxide (ITO), silver (Ag) and indium tin oxide (ITO), is formed on the second passivation layer 134. The third metal layer is patterned by performing a mask process to form the first electrode 138 electrically coupled to the drain electrode 124 through the second contact hole 136a. At substantially the same time, the third and the fourth auxiliary electrode 142a, 142b are formed. The third and fourth auxiliary electrodes 142a, 142b are electrically coupled to the first and the second auxiliary electrode 126, 128 through the third and the fourth contact hole 136b, 136c.

[0060] An insulating material such as polyimide (PI), for example, is formed on the first electrode 138. The insulating material is patterned by performing a mask process to form banks 144a at both sides of the first electrode 138. The insulating material is formed to be overlapped with a side edge of the first electrode 138 in the shape of surrounding each pixel area.

[0061] A negative photo resist may be formed on the banks 144a. The negative photo resist is patterned by performing a mask process to form the voltage drop prevention pattern 144b on a side upper portion of the third auxiliary electrode 142a. The voltage drop prevention pattern 144b is formed to be separated from the bank 144a, and is formed to have an inverse tapered shape.

[0062] When the voltage drop prevention pattern 144b is formed on a side upper portion of the third auxiliary electrode 142a as described above, the second electrode 152 is formed between the bank 144a and the voltage drop prevention pattern 144b. The second electrode 152 is formed between the voltage drop prevention pattern 144b and the bank 144a on the third auxiliary electrode 142a to electrically connect the third auxiliary electrode 142a to the first auxiliary electrode 126. When a voltage is applied through the first auxiliary electrode 126 from an external circuit, the first auxiliary electrode 126 is directly coupled to the second electrode 152 to prevent a voltage drop caused by a distance difference between an edge region of the panel and a central portion thereof. As a result, brightness uniformity can be maintained at a uniform level across all location within the panel.

[0063] Referring to FIG. 7D, an organic emitting layer 146 having a multilayer structure is formed at a front surface of the

substrate 110 including the bank 144a and the voltage drop prevention pattern 144b. When forming the organic emitting layer 146, thermal deposition using a shadow mask (not shown) having an opening portion and a blocking area is used to form the organic emitting layer 146 in a region surrounded by the bank 144a within each pixel area. The organic emitting layer 146 may be formed by including red, green and blue organic emission patterns (not shown) that emit red, green and blue colors, or with a white organic emission pattern (not shown) that emits white color. Thermal deposition using a shadow mask is performed three times when the organic emitting layer 146 is formed with red, green and blue organic emission patterns whereas thermal deposition using a shadow mask is performed once when the organic emitting layer 146 is formed with only a white organic emission pattern.

[0064] Referring to FIG. 7E, a transparent conductive material such as indium tin oxide (ITO) or indium zinc oxide (IZO), for example, is deposited at a front surface of the substrate 110 including the organic emitting layer 146. The transparent conductive material is patterned by performing a mask process to form the second electrode 152.

[0065] When the second electrode 152 is formed of indium tin oxide (ITO) or indium zinc oxide (IZO), a step coverage characteristic may be enhanced. As a result, the second electrode 152 can be formed between the bank 144a and voltage drop prevention pattern 144b and between the voltage drop prevention pattern 144b and bank 144a on the third auxiliary electrode 142a even though the voltage drop prevention pattern 144b is formed in an inverse tapered shape. As a result of forming the second electrode 152 in this manner, the second electrode 152 can be directly and electrically coupled to the third auxiliary electrode 142a without forming a contact hole.

[0066] In another embodiment where the first electrode 138 and second electrode 152 are configured with a cathode electrode and an anode electrode, respectively, the process can be carried out simply by changing materials constituting the first and the second electrode 138, 152 with each other.

[0067] Though not shown in the drawing, a seal pattern (not shown) is formed along an edge of the first substrate 110 on the completed first substrate 110, and the second substrate 170 having a transparent material is placed to face the first substrate 110. In one embodiment, the first and the second substrate 110, 170 are assembled with each other in an inert gas environment or vacuum environment to fabricate a top emission type organic electro-luminescence device according to an embodiment of the present invention.

[0068] On the other hand, a voltage drop prevention pattern of the organic electro-luminescence device according to the foregoing fabrication method is a separation space between adjacent banks having a structure in which a second electrode, i.e., cathode electrode, is deposited and directly brought into contact with a third auxiliary electrode, and there may occur a case that the cathode electrode is not normally brought into contact with the third auxiliary electrode due to its narrow separation space.

[0069] Hereinafter, an organic electro-luminescence device and a method of fabricating the same in which the foregoing problem is minimized according to the second embodiment of the present invention will be described.

[0070] Similarly to the first embodiment, the second embodiment relates a method of fabricating a top emission type organic electro-luminescence device in which the first electrode coupled to a drain electrode of the driving transistor

performs the role of an anode electrode and the second electrode performs the role of a cathode electrode.

[0071] FIGS. 8A through 8E are process cross-sectional views for each fabrication step illustrating one pixel area of an organic electro-luminescence device according to a second embodiment of the present invention.

[0072] According to the method of fabricating an organic electro-luminescence device in accordance with an embodiment 2 of the present invention, an inorganic insulating material made of silicon oxide (SiO₂), silicon nitride (SiN_x), or the like is deposited on the insulating substrate 210 to form the buffer layer 212 as illustrated in FIG. 8A. The step of forming the buffer layer 212 may be omitted.

[0073] Next, amorphous silicon is deposited on the buffer layer 212 to form an amorphous silicon layer (not shown), and then the amorphous silicon layer is crystallized into a polysilicon layer (not shown) by irradiating a laser beam or performing a thermal processing on the amorphous silicon. Then, a mask process is performed to pattern the polysilicon layer (not shown), thereby forming the semiconductor layer 213 in a pure polysilicon layer state.

[0074] Subsequently, silicon oxide (SiO₂), for example, is deposited on the semiconductor layer 213 with pure polysilicon to form the gate insulating layer 214. Then, a low resistance metal such as molybdenum tungsten (MoW), aluminium (Al), aluminium alloy (AlNd), copper (Cu) or the like is deposited on the gate insulating layer 214 to form a first metal layer (not shown), and a mask process is performed on the first metal layer to form the gate electrode 215 on the gate insulating layer 214 corresponding to the first area 213a of the semiconductor layer 213. At this time, though not shown in the drawing, a gate wiring (not shown) electrically coupled to the gate electrode is also formed.

[0075] Next, an impurity, i.e., a group III element or group V element, is doped into a front surface of the substrate 210 using the gate electrode 215 as a blocking mask to form the second areas 213b, 213c which are doped with impurities at a portion located at the outside of the gate electrode 215 of the semiconductor layer 213, and the first area 213a with pure polysilicon is formed at a portion where impurities are not doped by the gate electrode 215.

[0076] Subsequently, an inorganic insulating material, for example, silicon nitride (SiN_x) or silicon oxide (SiO₂), is deposited at a front surface of the substrate 210 formed with the semiconductor layer 213, divided into the first and the second areas 213a, 213b, 213c, to form the interlayer insulating layer 216, and the interlayer insulating layer 216 and the gate insulating layer 214 at a lower portion thereof are simultaneously patterned by performing a mask process. The mask process also creates the first contact hole 218 for exposing the second areas 213b, 213c, respectively.

[0077] Next, a second metal layer (not shown) having a single-layer or multilayer structure, containing at least one of titanium (Ti), aluminium (Al), and titanium (Ti), for example, is formed on the interlayer insulating layer 216. The second metal layer is patterned by performing a mask process to form the source and drain electrodes 222, 224. The second metal layer is electrically coupled to the second area 213b through the first contact hole 218. At this time, the first and the second auxiliary electrode 226, 228 are formed on the interlayer insulating layer 216. The foregoing first auxiliary electrode 226 is formed to be separated from the drain electrode 224, and the second auxiliary electrode 228 is formed to be separated from the first auxiliary electrode 226.

[0078] Subsequently, referring to FIG. 8B, an inorganic insulating material such as silicon nitride (SiN_x) and silicon oxide (SiO₂) is deposited at a front surface of the insulating substrate 210 including the source and drain electrodes 222, 224 to form the first passivation layer 232. An organic insulating material such as photo acryl (PA) is deposited on the first passivation layer 232 to form the second passivation layer 234. Next, the second contact hole 236a for exposing the drain electrode 224 and the third contact hole 236b for exposing the first auxiliary electrode 226 are formed on the first and the second passivation layers 232, 234. At the same time, the fourth contact hole 236c for exposing the second auxiliary electrode 228 is formed thereon.

[0079] Next, referring to FIG. 8C, a third metal layer (not shown) having a multilayer structure made of at least one of indium tin oxide (ITO), silver (Ag) and indium tin oxide (ITO) is formed on the second passivation layer 234. The third metal layer is patterned by performing a mask process to form the first electrode 238 electrically coupled to the drain electrode 224 through the second contact hole 236a. At the same time, the third and the fourth auxiliary electrode 242a, 242b are formed. The third and fourth auxiliary electrodes 242a, 242b are electrically coupled to the first and the second auxiliary electrode 226, 228 through the third and the fourth contact hole 236b, 236c.

[0080] Subsequently, an insulating material such as polyimide (PI), for example, is formed on the first electrode 238. The insulating material is patterned by performing a mask process to form banks 244a at both sides of the first electrode 238. The banks 244a are formed to be overlapped with a side edge of the first electrode 238 in the shape of surrounding each pixel area.

[0081] Subsequently, a negative photo resist may be formed on the banks 244a. The negative photo resist is patterned by performing a mask process to form the voltage drop prevention pattern 244b on a side upper portion of the third auxiliary electrode 242a. In this case, the voltage drop prevention pattern 244b is formed to be separated from the bank 244a, and is formed to have an inverse tapered shape.

[0082] The voltage drop prevention pattern 244b may be configured in a double layered shape having a step such that the lower portion thereof has a width remarkably smaller than that of the upper portion thereof or configured in such a shape that a victim pattern 254 is further formed between the third auxiliary electrodes 238 at the lower portion thereof.

[0083] In particular, when the victim pattern 254 is further formed at a lower portion of the voltage drop prevention pattern 244b, a victim pattern material layer (not shown) is formed at a lower portion of the foregoing negative photoresist, and the victim pattern 254 and voltage drop prevention pattern 244b are patterned at the same time. To this end, the victim pattern material layer uses a material having a different etching selection ratio from at least one of the third auxiliary electrode 238 at the lower portion thereof and the voltage drop prevention pattern 244b at the upper portion thereof.

[0084] At least one of silicon nitride (SiN_x), silicon oxide (SiO₂), amorphous silicon (a-Si), aluminium (Al), aluminium-neodymium alloy (AlNd), and copper (Cu) may be used for the material forming the foregoing victim pattern 254.

[0085] According to the structure, the second electrode 252 is formed between the bank 244a and the voltage drop prevention pattern 244b and between the voltage drop prevention pattern 244b and the bank 244a on the third auxiliary elec-

trode **242a** when forming the second electrode **252** by the voltage drop prevention pattern **244b** at a side upper portion of the third auxiliary electrode **242a** and electrically coupled with the third auxiliary electrode **242a** and the first auxiliary electrode **226**. Furthermore, a space in which the second electrode **252** is deposited between a lower portion of the voltage drop prevention pattern **244b** and the third auxiliary electrode **242a** is further secured by the victim pattern **254**.

[0086] Accordingly, when a voltage is applied through the first auxiliary electrode **226** from the outside, an area on which the first auxiliary electrode **226** is brought into contact with the second electrode **252** to be formed in the subsequent process is further secured, and the first auxiliary electrode **226** is normally deposited on the third auxiliary electrode **242a**.

[0087] Next, referring to FIG. 8D, an organic emitting layer **246** having a multilayer structure is formed at a front surface of the substrate **210** including the bank **244a** and the voltage drop prevention pattern **244b**. When forming the organic emitting layer **246**, thermal deposition using a shadow mask (not shown) having an opening portion and a blocking area is carried out to form the organic emitting layer **246** in a region surrounded by the bank **244a** within each pixel area. The organic emitting layer **246** may be formed by including red, green and blue organic emission patterns (not shown) that emit red, green and blue colors, or with only a white organic emission pattern (not shown) that emits white color, and a shadow mask process may be also performed three times or once.

[0088] Subsequently, referring to FIG. 8E, a transparent conductive material such as indium tin oxide (ITO) or indium zinc oxide (IZO) is deposited at a front surface of the substrate **210** including the organic emitting layer **246**. The transparent conductive material is patterned by performing a mask process to form the second electrode **252**.

[0089] The indium tin oxide (ITO) or indium zinc oxide (IZO) has a good step coverage characteristic, and the second electrode **252** is formed between the bank **244a** and voltage drop prevention pattern **244b** and between the voltage drop prevention pattern **244b** and bank **244a** on the third auxiliary electrode **242a** even though the voltage drop prevention pattern **244b** is formed in an inverse tapered shape. As a result, the second electrode **252** can be directly and electrically coupled to the third auxiliary electrode **242a** without forming an additional contact hole.

[0090] FIG. 9 is an enlarged view illustrating a portion B in FIG. 8E. As illustrated in the drawing, the second electrode **252** is deposited between the bank **244a** and the voltage drop prevention pattern **244b** and thus directly brought into contact with the exposed third auxiliary electrode **242a**. In particular, a gap (g) is further secured between a lower portion of the voltage drop prevention pattern **244b** and an upper portion of the third auxiliary electrode **242a** by a width difference between the voltage drop prevention pattern **244b** and the victim pattern **254**, and the second electrode **252** is formed in the gap (g) and thus stably coupled thereto.

[0091] Hereinafter, though not shown in the drawing, a seal pattern (not shown) is formed along an edge of the first substrate **210** on the completed first substrate **210**, and the second substrate (not shown) having a transparent material is bonded thereto, thereby fabricating a top emission type organic electro-luminescence device according to the second embodiment of the present invention.

[0092] Although many embodiments have been specifically disclosed in the foregoing description, they should be

construed as an illustration of preferred embodiments rather than limitations to the scope of invention. Consequently, the scope of the invention should not be determined by the embodiments specifically disclosed herein but instead by the claims and equivalents thereof.

What is claimed is:

1. An organic electro-luminescence device, comprising:
 - a bank layer formed over a substrate, the bank layer including a first, second, and third portion;
 - a first electrode formed between the first and second portions of the bank layer;
 - an auxiliary electrode, at least a part of the auxiliary electrode formed between the second and third portions of the bank layer;
 - a voltage drop prevention pattern formed on the auxiliary electrode;
 - an organic material layer formed between the first and second portions of the bank layer; and
 - a second electrode formed on the organic material layer, at least a portion of the second electrode electrically coupled to the auxiliary electrode.
2. The organic electro-luminescence device of claim 1, wherein the voltage drop prevention pattern is a negative photoresist.
3. The organic electro-luminescence device of claim 1, wherein the voltage drop prevention pattern has an inverse tapered shape.
4. The organic electro-luminescence device of claim 3, wherein the voltage drop prevention pattern has a top width greater than a bottom width.
5. The organic electro-luminescence device of claim 1, wherein the organic material layer is formed without physically contacting the auxiliary electrode.
6. The organic electro-luminescence device of claim 1, wherein the second electrode is between the voltage drop prevention pattern and the second portion of the bank.
7. The organic electro-luminescence device of claim 1, wherein the second electrode is between the voltage drop prevention pattern and the third portion of the bank.
8. The organic electro-luminescence device of claim 1, wherein at least a part of the voltage drop prevention pattern is formed between the second and third portions of the bank.
9. The organic electro-luminescence device of claim 1, wherein the organic material forms an emission area of the organic electro-luminescence device, and at least a portion of the voltage drop prevention pattern is formed outside of the emission area.
10. The organic electro-luminescence device of claim 1, wherein an emission area is formed between the first and second portions of the bank, and at least a portion of the voltage drop prevention pattern is formed outside of the emission area.
11. The organic electro-luminescence device of claim 1, wherein a height of the voltage drop prevention pattern is greater than or equal to a height of the second portion of the bank.
12. The organic electro-luminescence device of claim 1, wherein the voltage drop prevention pattern has a double layered inverse tapered shape having a step.
13. The organic electro-luminescence device of claim 1, wherein a victim pattern is further formed at a lower portion of the voltage drop prevention pattern.
14. The organic electro-luminescence device of claim 13, wherein the victim pattern is formed of a material having a

different etching selection ratio from at least one of the auxiliary electrode and the voltage drop prevention pattern.

15. The organic electro-luminescence device of claim **14**, wherein the victim pattern comprises at least one of silicon nitride (SiNx), silicon oxide (SiO₂), amorphous silicon (a-Si), aluminium (Al), aluminium-neodymium alloy (AlNd), and copper (Cu).

16. A method of fabricating an organic electro-luminescence device, the method comprising:

forming a bank layer over a substrate, the bank layer including a first, second, and third portion;

forming a first electrode between the first and second portions of the bank layer;

forming an auxiliary electrode, at least a part of the auxiliary electrode formed between the second and third portions of the bank layer;

forming a voltage drop prevention pattern on the auxiliary electrode;

forming an organic material layer between the first and second portions of the bank layer; and

forming a second electrode on the organic material layer, at least a portion of the second electrode electrically coupled to the auxiliary electrode.

17. The method of claim **16**, wherein the voltage drop prevention pattern is a negative photoresist.

18. The method of claim **16**, wherein the voltage drop prevention pattern has an inverse tapered shape.

19. The method of claim **16**, wherein the voltage drop prevention pattern has a top width greater than a bottom width.

20. The method of claim **16**, wherein the voltage drop prevention pattern prevents the organic material layer from physically contacting the auxiliary electrode while allowing the second electrode to physically and electrically couple to the auxiliary electrode while the organic material layer and the second electrode are formed.

21. The method of claim **16**, wherein the organic material layer is formed without physically contacting the auxiliary electrode.

22. The method of claim **16**, wherein the second electrode is formed between the voltage drop prevention pattern and the second part of the bank.

23. The method of claim **16**, wherein the second electrode is formed between the voltage drop prevention pattern and the third part of the bank.

24. The method of claim **16**, wherein at least a part of the voltage drop prevention pattern is formed between the second and third portions of the bank.

25. The method of claim **16**, wherein the organic material forms an emission area of the organic electro-luminescence device, and at least a portion of the voltage drop prevention pattern is formed outside of the emission area.

26. The method of claim **16**, wherein an emission area is formed between the first and second portions of the bank, and at least a portion of the voltage drop prevention pattern is formed outside of the emission area.

27. The method of claim **16**, wherein a height of the voltage drop prevention pattern is greater than or equal to a height of the second portion of the bank.

28. The method of claim **16**, wherein the voltage drop prevention pattern has a double layered inverse tapered shape having a step.

29. The method of claim **16**, further comprising forming a victim pattern at a lower portion of the voltage drop prevention pattern.

30. The method of claim **29**, wherein the victim pattern is formed of a material having a different etching selection ratio from at least one of the auxiliary electrode and the voltage drop prevention pattern.

31. The method of claim **30**, wherein the victim pattern comprises at least one of silicon nitride (SiNx), silicon oxide (SiO₂), amorphous silicon (a-Si), aluminium (Al), aluminium-neodymium alloy (AlNd), and copper (Cu).

* * * * *

专利名称(译)	有机发光显示装置及其制造方法		
公开(公告)号	US20130099218A1	公开(公告)日	2013-04-25
申请号	US13/707310	申请日	2012-12-06
[标]申请(专利权)人(译)	乐金显示有限公司		
申请(专利权)人(译)	LG DISPLAY CO. , LTD. ,		
当前申请(专利权)人(译)	LG DISPLAY CO. , LTD.		
[标]发明人	LEE JOON SUK KIM SE JUNE YOO JUHNSUK		
发明人	LEE, JOON-SUK KIM, SE-JUNE YOO, JUHNSUK		
IPC分类号	H01L51/52 H01L51/50		
CPC分类号	H01L51/5203 H01L51/5012 H01L27/3279 H01L27/3246 H01L27/1259 H01L51/5228		
优先权	1020110089277 2011-09-02 KR		
其他公开文献	US8963137		
外部链接	Espacenet USPTO		

摘要(译)

本发明描述了一种能够降低阴极电阻以提高器件内每个位置的亮度均匀性的有机电致发光器件。有机电致发光器件包括形成在衬底上的堤层，堤层包括第一，第二和第三部分。在堤层的第一和第二部分之间形成第一电极。形成辅助电极，其中辅助电极的至少一部分形成在堤层的第二和第三部分之间。在辅助电极上形成电压降防止图案。在堤层的第一和第二部分之间形成有机材料层。形成在有机材料层上的第二电极，其中第二电极的至少一部分电耦合到辅助电极。

